

DESCRIPTION

PSV-1225 is an up-to date power supply unit with battery backup compliant with EN regulations for social and security alarm systems. Unit provides all features required by EN 50131-6:2008, security grade 3.

Distinctive and unique feature of PSV-1225 is invented by Alarmtech ViP mode – Voltage-in-Parallel. Power supply units with ViP feature can be connected in parallel both (+) and (-) on one common power bus without a need of additional synchronization. Connected units will share load on a bus. ViP feature can be used to build distributed and redundant power systems. It can be also used to compensate voltage drops on a bus by placing power supply units in distant bus sections.

Power conversion is based on high frequency SMPS regulator providing high conversion efficiency. Low losses inside unit preserve batteries from overheating shortening battery life time. Computerized battery recharging circuit works in constant current – limited voltage mode – the most advanced and the best mode to provide the longest possible battery life time.

Power unit is equipped with built-in diagnostic system detecting and signalling mains failure, different battery failures including end-of-life warning, output faults like low voltage or broken fuse.

MAIN FEATURES

- EN 50131-6:2008 compliant, security grade 3
- Type A, with backup battery
- Nominal output voltage- 13,8V
- Total current capacity – 2,5A
- ViP (Voltage-in-Parallel) feature increasing reliability and capacity of power supply systems – any number of power supplies with ViP feature can be connected (+) and (-) in parallel to same bus without need for additional synchronization
- Programmed to work with 18 Ah batteries
- Short circuit and overload protection
- Lack of mains detection
- Low output voltage detection
- Broken fuse detection and identification
- Detection of power unit failure
- Over-voltage protection
- Detection of different battery faults
- Deep discharge protection of battery
- Remote and local battery testing
- Tamper security provided (case opening and pry-off detection)
- Built-in real time diagnostic system with fault visualisation and localisation by LED on PCB

APPLICATIONS

- Intruder alarm systems
- Social alarm systems
- Access control systems

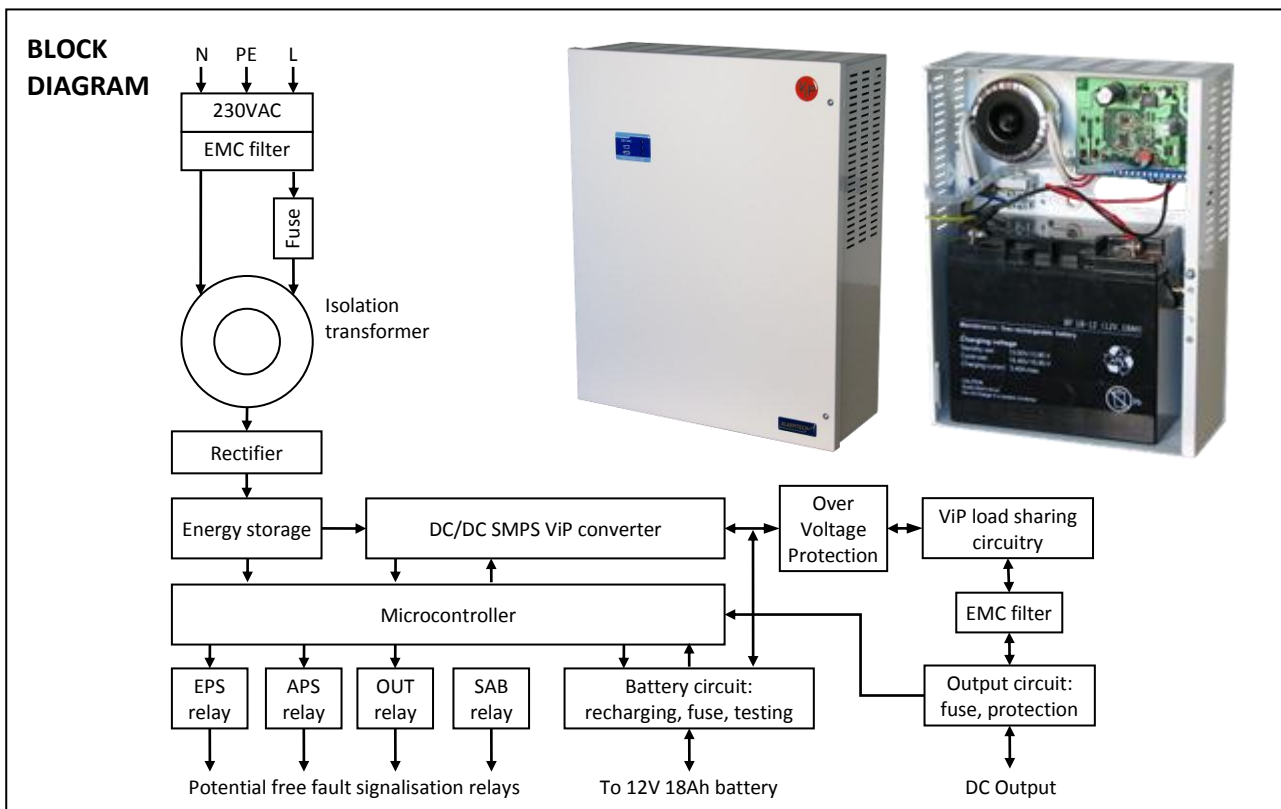

1. INSTALLATION

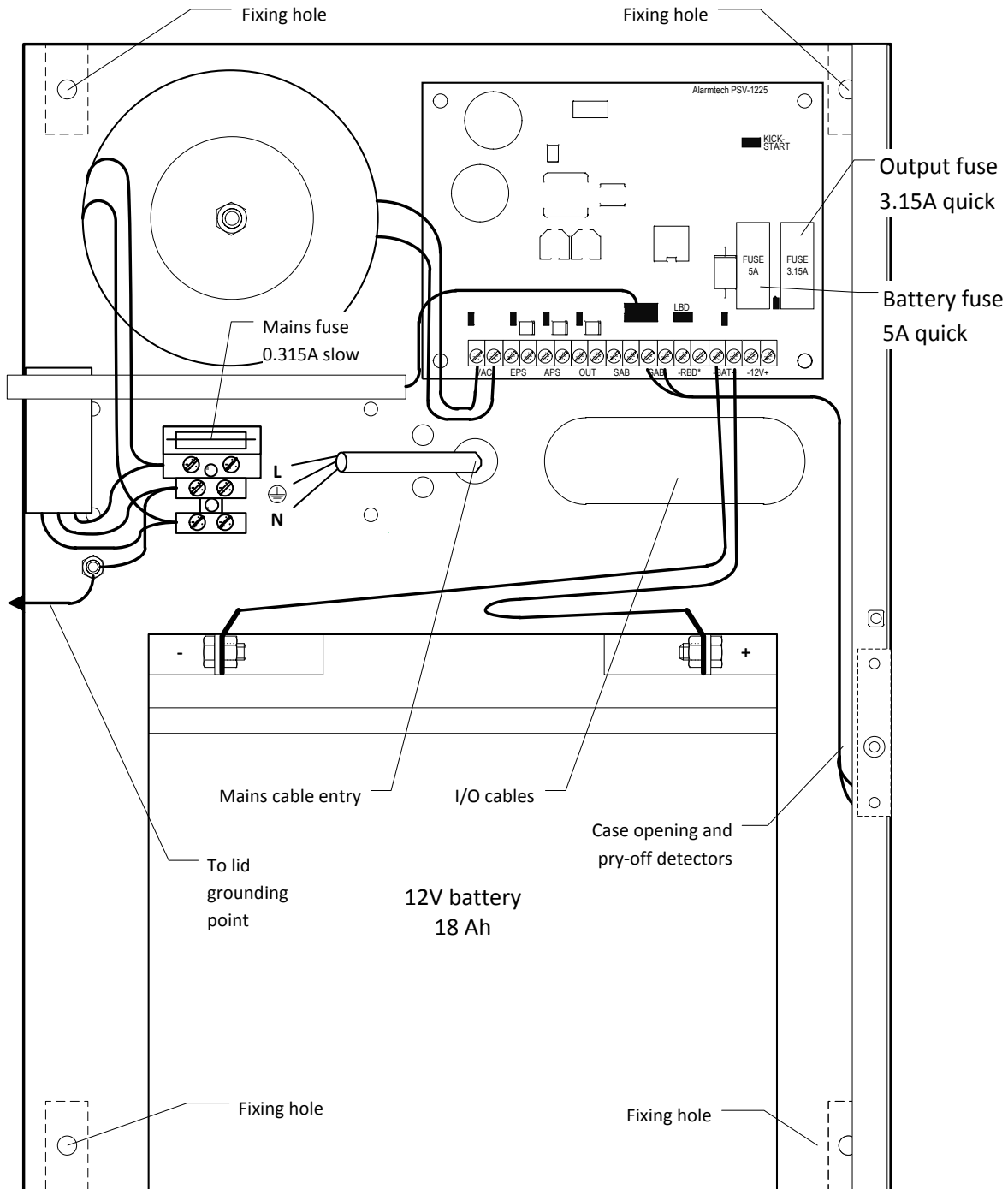

PSV-1225 power supply installation and start-up procedure:

- Fix unit in destination place using 4 fixing holes
- Place sealed lead acid battery 12V/18Ah in battery chamber
- Make connection between left battery (-) and battery connector using black battery cable
- Make connection between right battery (+) and battery connector using red battery cable
- Make appropriate connections between power output and power receivers
- Make required connections between signalling outputs of PSV-1225 unit and cooperating units (outputs EPS, APS, OUT, SAB, input -RBT*)
- Make sure that cable delivering 230VAC to power supply is disconnected from mains
- Connect 230 VAC cable to 230 VAC input in power supply unit – make sure that PE cable is connected to PE input
- Switch on mains delivering energy to power supply - PSV-1225 unit will start automatically delivering power to the load and monitoring state of PS

2. TECHNICAL DESCRIPTION

2.1 Front panel

Power supply unit is equipped with front panel showing actual general state of unit. Three LED's display shows:

- Green LED: mains voltage present – unit in EPS mode supplied from mains
- Yellow LED: mains voltage missing – unit in APS mode supplied from battery
- Red LED: fault detected – quick visual identification and localisation of failure is possible with help of set of diagnostic LED's in power unit

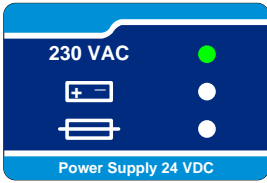

Unit state OK
Supplied from mains
Battery OK
Output OK
No faults reported

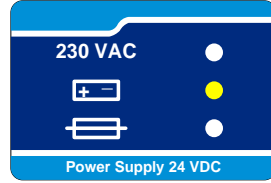

Missing mains
(EPS output triggered)
Supplied from battery
No other faults

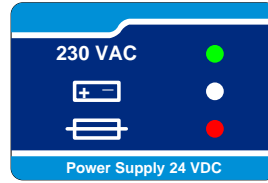

PS supplied from mains
Possible fault detected:
APS (battery)
OUT (output)

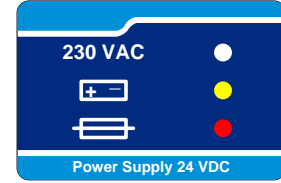

Missing mains
(EPS output triggered)
Supplied from battery
Possible faults detected:
APS (battery),
OUT (output)

2.2 Internal state monitoring functions in power unit

All monitored states of PS are displayed with help of LED diodes for quick visual identification. The placement of monitoring LED is documented in below placed drawings. The meaning of LED colours is following:

- Green - normal state, OK
- Red - fault detected
- Yellow - informative meaning (neutral)

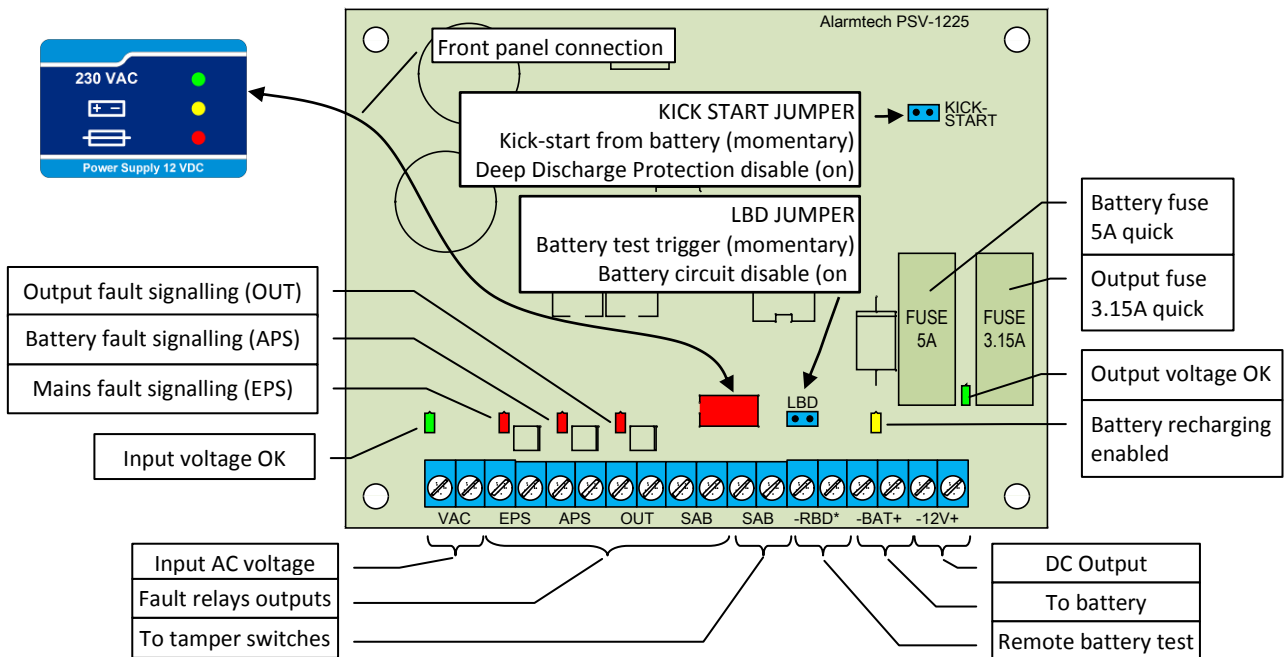

2.3 Jumpers in power unit

Power unit is equipped with 2 jumpers placed on PCB:

- Kick-start jumper (default position: open)

Momentary shunt	Kick-start of PS from battery (w/o mains)
Open (default)	Deep Discharge Protection (DDP) of battery enabled
Closed	Deep Discharge Protection (DDP) of battery disabled

- LBD (Local Battery Diagnostics) jumper (default position: open)

Momentary shunt	Battery test trigger (30s test of internal battery resistance)
Open (default)	Battery recharging circuit enabled
Closed	Battery recharging circuit disabled

2.4 Inputs and outputs in power unit

Input/Output	Marking	Description
Power output	-12V+	Two (-) and two (+) terminals for power output
Battery pack connection	-BAT+	(-) and (+) terminals for 2V battery connection
AC voltage input with PE	VAC	AC voltage input from isolation transformer
Mains failure signalling	EPS	Potential free NC opto-relay output signalling EPS fault
Battery failure signalling	APS	Potential free NC opto-relay output signalling APS fault
Output failure signalling	OUT	Potential free NC opto-relay output signalling OUT fault
Remote Battery Diagnostics trigger	-RBD*	Test triggered by momentary shunt between (-) and (*)
Tamper detection signalling	SAB	Potential free NC micro-switch output

3. TECHNICAL SPECIFICATION

INPUT SPECIFICATION

Voltage:	230 VAC nominal, +10% ÷ -15%	Current:	0,2 A at maximal load
Frequency:	50 Hz	Mains fuse:	0,315A, 5x20mm type F

OUTPUT SPECIFICATION

Type of Power Supply acc. to EN 50131-6:2008:	type A
Security grade acc. to EN 50131-6:2008:	grade 3
Nominal output voltage:	13,8 V
Maximal output voltage:	14,5 V
Minimal output voltage:	10,0 V (in APS mode)
Total maximal current (load and battery recharging):	2,5 A
Total rated output current:	2,2 A
Quiescent current internally consumed in PS:	0,03 A
Maximal output Vpp ripple voltage:	<5% of nominal output voltage
Output fuse:	3,15A, 5x20 mm type F

BATTERY

Battery type:	12V, 18Ah battery
Battery recharging method:	constant current – limited voltage
Maximal battery recharging current:	0,25 A
Time to recharge 18 Ah batteries to 80%:	58h max (< 72h)
Battery voltage triggering APS fault:	11 V
Battery voltage triggering DDP circuit:	10 V
Output voltage triggering OUTPUT fault:	9 V
Battery fuse:	5A, 5x20 mm type F

MONITORING OUTPUTS

EPS – loss of mains	APS – battery pack low voltage, battery failure
OUT – output voltage low, power unit failure	SAB – case tampering (opening or pry-off)
Electrical characteristics of monitoring outputs:	- Potential free semiconductor relay for EPS, APS, OUT fault signalling - Micro-switch for case tampering signaling
Logical characteristics of monitoring signals:	Closed state – monitored condition not present Open state – monitored condition present

ENVIRONMENT

Environmental Class acc. to EN 50130-5:1998:	Class I
Operating temperature and humidity range:	+5°C...+40°C, RH to 90%, no condensation

WEIGHT AND DIMENSIONS

Weight without battery:	approx. 1,7 kg
Weight with battery (18Ah):	approx. 7,2 kg
Dimensions:	250 x 330 x 100 mm (W x H x D)